

HI-IF Single-Chip Broadband TV Tuners

General Description

The MAX3550/MAX3551/MAX3553 low-cost, broadband, dual-conversion tuner ICs are designed for use in analog and digital television receivers. Each IC integrates all necessary RF functions, including an integrated HI-IF filter, fully integrated VCOs, and an integrated IF VGA. The operating frequency range extends from 50MHz to 878MHz while providing over 60dB RF/IF gain-control range. The MAX3550/MAX3551 have an IF frequency centered at 44MHz, while the MAX3553 has an IF output centered at 36MHz.

These devices include a variable-gain front end, achieving an overall 8dB noise figure. A dual synthesizer generates both local oscillator (LO) frequencies, providing superior phase noise performance of -86dBc/Hz at 10kHz. The integrated HI-IF filter achieves 68dBc of image rejection. Only an IF SAW filter, passive loop filters, and a crystal are needed to complete a single-chip tuner. Device programming and configuration are accomplished with a 3-wire serial interface for the MAX3550, and with a 2-wire serial interface for the MAX3551/MAX3553.

The MAX3550/MAX3551/MAX3553 are available in a 48-pin QFN-EP package and are specified for the commercial (0°C to +70°C) temperature range.

Applications

Analog/Digital Cable Set-Top Boxes
OpenCable™ Television Receivers
DVB-T Digital Terrestrial Receivers
ATSC Digital Terrestrial Receivers
Cable Modems

Selector Guide

PART	SERIAL INTERFACE	IF CENTER FREQUENCY
MAX3550	3-Wire	44MHz
MAX3551	2-Wire	44MHz
MAX3553	2-Wire	36MHz

OpenCable is a trademark of CableLabs.

Features

- ◆ Fully Integrated HI-IF Filter
- ◆ Fully Integrated VCOs, No External Components or Traces
- ◆ Low 8dB Noise Figure
- ◆ High Linearity—+19dBm IIP3 and +52dBm IIP2
- ◆ Industry's Smallest Footprint
- ◆ Superior Phase Noise for 256-QAM, 8-VSB, and COFDM

Ordering Information

PART	TEMP RANGE	PIN-PACKAGE
MAX3550CGM	0°C to +70°C	48 QFN-EP*
MAX3551CGM	0°C to +70°C	48 QFN-EP*
MAX3553CGM	0°C to +70°C	48 QFN-EP*

*EP = Exposed paddle.

Pin Configurations/ Functional Diagrams

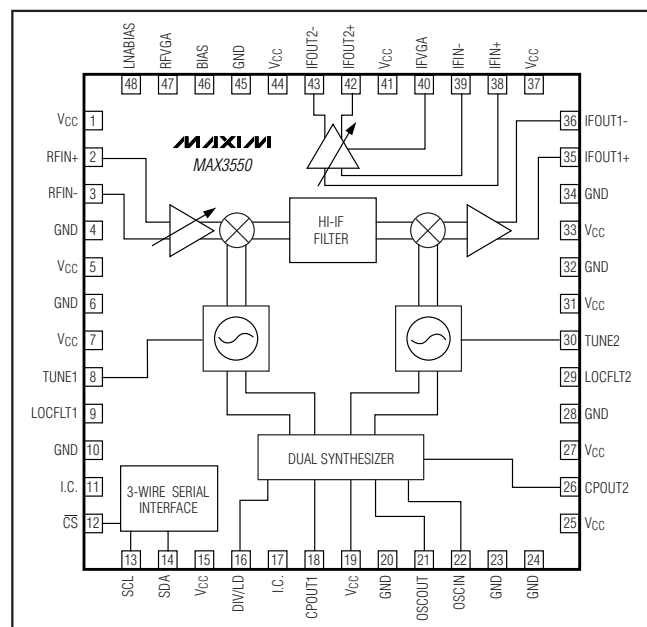

Pin Configurations/Functional Diagrams continued at end of data sheet.

HI-IF Single-Chip Broadband TV Tuners

ABSOLUTE MAXIMUM RATINGS

V _{CC} to GND	-0.3V to +5.5V	Continuous Power Dissipation (T _A = +70°C)
IFIN ₋ , IFOUT1 ₋ , IFOUT2 ₋ , RFIN ₋ , TUNE ₋ , LOCFLT ₋ , CPOUT ₋ , OSCIN, OSCOUT, IFVGA, RFVGA, BIAS, LNABIAS, ADDR ₋ , CS, SCL, SDA, DIV/LD	-0.3V to (V _{CC} + 0.3V)	48-Pin QFN (derate 27mW/°C above +70°C)2162mW
		Operating Temperature Range.....0°C to +70°C
		Junction Temperature+150°C
		Storage Temperature Range-65°C to +150°C
		Lead Temperature (soldering, 10s)+300°C

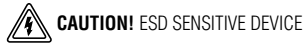

Stresses beyond those listed under "Absolute Maximum Ratings" may cause permanent damage to the device. These are stress ratings only, and functional operation of the device at these or any other conditions beyond those indicated in the operational sections of the specifications is not implied. Exposure to absolute maximum rating conditions for extended periods may affect device reliability.

DC ELECTRICAL CHARACTERISTICS

(MAX355_ EV kit, V_{CC} = +4.75V to +5.25V, R_{BIAS} = 5.9kΩ ±1%, no AC signal applied, T_A = 0°C to +70°C, unless otherwise noted. Typical values are at V_{CC} = +5.0V, T_A = +25°C, unless otherwise noted.) (Note 1)

PARAMETER	CONDITIONS	MIN	TYP	MAX	UNITS
SUPPLY VOLTAGE AND SUPPLY CURRENT					
Supply Voltage		4.75		5.25	V
Supply Current	At T _A = +25°C, V _{RFVGA} = +3.0V		320		mA
	At T _A = +70°C, V _{RFVGA} = +0.5V			385	
RF and IF VGA Input Bias Current	V _{RFVGA} = V _{IFVGA} = +0.5V and +3.0V	-50		+50	μA
RF and IF VGA Control Voltage	Maximum gain	3			V
	Minimum gain			0.5	
LOGIC INTERFACE					
Input-Logic Low (V _{IL})				0.9	V
Input-Logic High (V _{IH})		2.3			V
Input Logic Current		-10		+10	μA
Output-Logic Low	Sink current = 3mA			0.4	V
Output-Logic High	Source current = 3mA	2.8			V

HI-IF Single-Chip Broadband TV Tuners

MAX3550/MAX3551/MAX3553

AC ELECTRICAL CHARACTERISTICS

(MAX355_ EV kit, $V_{CC} = +4.75V$ to $+5.25V$, $R_{BIAS} = 5.9k\Omega \pm 1\%$, **inputs terminated to 75 Ω** , $f_{RFIN} = 50MHz$ to $878MHz$, $f_{IF} = 45.75MHz$ (MAX3550/MAX3551), $f_{IF} = 38.9MHz$ (MAX3553), $f_{COMP1} = 1MHz$, $f_{COMP2} = 62.5kHz$, $T_A = 0^\circ C$ to $+70^\circ C$, unless otherwise noted. Typical values are at $V_{CC} = +5.0V$, $T_A = +25^\circ C$, unless otherwise noted.) (Note 1)

PARAMETER	CONDITIONS	MIN	TYP	MAX	UNITS	
OVERALL REQUIREMENTS (RF INPUT TO 1st IF OUTPUT)						
Operating Frequency Range	Gain specification met across this frequency band	50		878	MHz	
Input Return Loss	Worst case across band, 75 Ω , any RFVGA setting		8		dB	
Voltage Gain	$Z_{SOURCE} = 75\Omega$, $Z_{LOAD} = 200\Omega$, RFVGA = +3.0V	$T_A = +25^\circ C$	31.5	38.5	45.0	dB
		$T_A = +70^\circ C$	30.0	37	43.5	
Gain-Reduction Range	Measured at 50MHz	30			dB	
Gain Flatness	RFVGA = +3.0V at $f_{RFIN} = 878MHz$ vs. 50MHz	-1.5		+1.5	dB	
	RFVGA = 0.5V at $f_{RFIN} = 878MHz$ vs. 50MHz	-2		+2		
Noise Figure	RFVGA = +3.0V		7.9		dB	
IIP2	RFVGA = +3.0V, $T_A = +25^\circ C$ to $+70^\circ C$, $V_{CC} = 4.85V$ to $5.15V$, $f_{RF} = 860MHz$		34		dBm	
	At 12dB gain reduction, $T_A = +25^\circ C$ to $+70^\circ C$, $V_{CC} = 4.85V$ to $5.15V$, $f_{RF} = 860MHz$		52.5			
IIP3	RFVGA = +3.0V, $T_A = +25^\circ C$ to $+70^\circ C$, $V_{CC} = 4.85V$ to $5.15V$		+8		dBm	
	At 12dB gain reduction, $T_A = +25^\circ C$ to $+70^\circ C$, $V_{CC} = 4.85V$ to $5.15V$		+18			
Beats Within Output	0dBmV PIX carrier level (Note 2)		-68		dBc	
Channel Flatness	From PIX to (PIX + 4) MHz	-0.5	0.3	+1.0	dB	
Isolation	5MHz to 150MHz, RF input to IF output (Note 3)	-63	-68		dBc	
Image Rejection	Measured at 91MHz above desired PIX (MAX3550/MAX3551)	62	68		dBc	
	Measured at 77.75MHz above desired PIX (MAX3553)	60	66			
Spurious at RF Input (Note 3)	50MHz to 878MHz		-54	-48	dBmV	
	Above 878MHz (LO and LO harmonics)			+3		
Single Sideband Phase Noise	$f_{OFFSET} = 1kHz$		-62		dBc/Hz	
	$f_{OFFSET} = 10kHz$, $BW_{LOOP} = 2.5kHz$		-86			
	$f_{OFFSET} = 100kHz$, $BW_{LOOP} = 2.5kHz$		-105			
Output Return Loss	Balanced, 50 Ω		9		dB	

HI-IF Single-Chip Broadband TV Tuners

MAX3550/MAX3551/MAX3553

AC ELECTRICAL CHARACTERISTICS

(MAX355_ EV kit, $V_{CC} = +4.75V$ to $+5.25V$, $R_{BIAS} = 5.9k\Omega \pm 1\%$, **inputs terminated to $1k\Omega$** , $Z_{LOAD} = 300\Omega$, $f_{IF} = 40MHz$ to $48MHz$, $T_A = 0^\circ C$ to $+70^\circ C$, unless otherwise noted. Typical values are at $V_{CC} = +5.0V$, $T_A = +25^\circ C$, unless otherwise noted.) (Note 1)

PARAMETER	CONDITIONS	MIN	TYP	MAX	UNITS
SECOND IF STAGE					
Input Impedance	Balanced		1.7		k Ω
Output Impedance	Balanced (Note 3)			100	Ω
Passband Voltage Gain	$Z_{SOURCE} = 1.1k\Omega$, $Z_{LOAD} = 300\Omega$, $V_{IFVGA} = +3.0V$	50	53	57	dB
	$V_{IFVGA} = +0.5V$		14.5	23	
Passband Flatness	From PIX to (PIX - 4) MHz for 45.75MHz PIX frequency (Note 3)			0.2	dB
Maximum Output Voltage			3.2		V _{P-P}
VGA Gain Slope	$V_{IFVGA} = +3.0V$ to $+0.5V$	10		20	dB/V
-3dB Bandwidth	(Note 3)			180	MHz
Noise Figure	$f_{IF} = 44MHz$, $V_{IFVGA} = +3.0V$		5.1		dB
Noise Figure vs. Attenuation	First 10dB back-off		0.3		dB/dB
IIP3	Gain = 45dB, $V_{OUT} = 1.5V_{P-P}$		-27.5		dBm
	Gain = 27dB, $V_{OUT} = 1.5V_{P-P}$		-11.3		
OIP3	$V_{OUT} = 1.5V_{P-P}$, $V_{IFVGA} = +3.0V$ to $+0.5V$ (Note 3)		25		dBm
PSRR	50mV _{P-P} at 200kHz		-57		dB

HI-IF Single-Chip Broadband TV Tuners

MAX3550/MAX3551/MAX3553

SYNTHESIZER ELECTRICAL CHARACTERISTICS

(MAX355_ EV kit, $V_{CC} = +4.75V$ to $+5.25V$, $R_{BIAS} = 5.9k\Omega \pm 1\%$, $f_{COMP1} = 1MHz$, $f_{COMP2} = 62.5kHz$, $T_A = 0^\circ C$ to $+70^\circ C$, unless otherwise noted. Typical values are at $V_{CC} = +5.0V$, $T_A = +25^\circ C$, unless otherwise noted.) (Note 1)

PARAMETER	CONDITIONS	MIN	TYP	MAX	UNITS
1st LOCAL OSCILLATOR (LO1)					
Tuning Range		1274		2111	MHz
VCO Tuning Gain		40		120	MHz/V
1st LOCAL OSCILLATOR (LO1) DIVIDER					
RF1 N-Divider Ratio		256		8191	
RF1 R-Divider Ratio		1		31	
1st LOCAL OSCILLATOR (LO1) PHASE DETECTOR AND CHARGE PUMP					
Phase-Detector Phase Noise	$f_{OFFSET} = 2kHz$ (Note 3)			-142	dBc
Charge-Pump Source/Sink Matching	Correlate locked vs. unlocked			6	%
Charge-Pump Tri-State Current	RF1	-20		+20	nA
2nd LOCAL OSCILLATOR (LO2)					
Tuning Range		1175		1193	MHz
VCO Tuning Gain		25		70	MHz/V
2nd LOCAL OSCILLATOR (LO2) DIVIDER					
RF2 N-Divider Ratio		512		65,535	
RF2 R-Divider Ratio		2		127	
2nd LOCAL OSCILLATOR (LO2) PHASE DETECTOR AND CHARGE PUMP					
Phase-Detector Phase Noise	$f_{OFFSET} = 2kHz$ (Note 3)			-142	dBc
Charge-Pump Source/Sink Matching	Correlate locked vs. unlocked			6	%
Charge-Pump Tri-State Current	RF2	-7		+7	nA

LOGIC INTERFACE

(MAX355_ EV kit, $V_{CC} = +4.75V$ to $+5.25V$, $R_{BIAS} = 5.9k\Omega \pm 1\%$, $T_A = 0^\circ C$ to $+70^\circ C$, unless otherwise noted.) (Note 1)

PARAMETER	CONDITIONS	MIN	TYP	MAX	UNITS
Maximum Clock Frequency		400			kHz

Note 1: These parameters are production tested from $T_A = +25^\circ C$ to $+70^\circ C$, and are guaranteed by design and characterization at $T_A = 0^\circ C$.

Note 2: When using the tuning table provided in EV kit documentation.

Note 3: These parameters are guaranteed by design and characterization, and are not production tested.

HI-IF Single-Chip Broadband TV Tuners

Typical Operating Characteristics

(MAX355_ EV kit, $V_{CC} = +5.0V$, $R_{BIAS} = 5.9k\Omega$, $f_{RF} = 860MHz$, $f_{IF} = 44MHz$ (MAX3550/MAX3551), $36MHz$ (MAX3553), $T_A = +25^\circ C$, unless otherwise noted.)

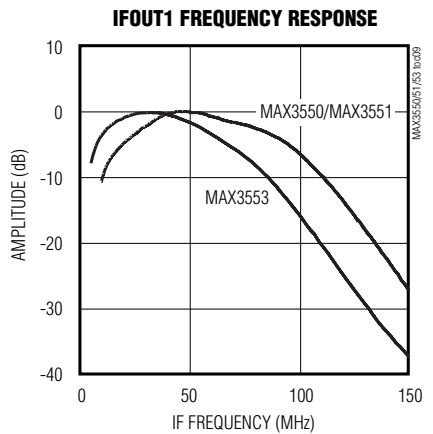
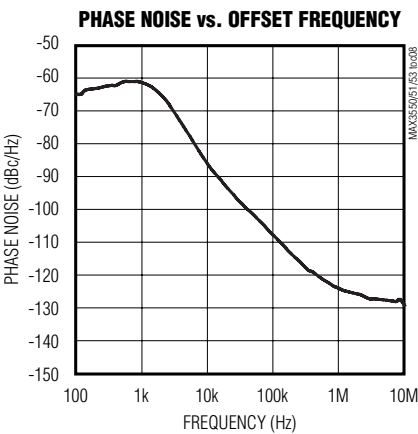
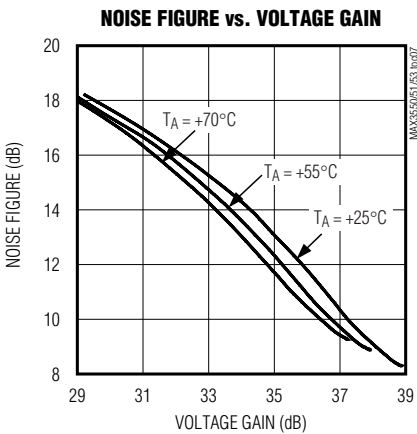
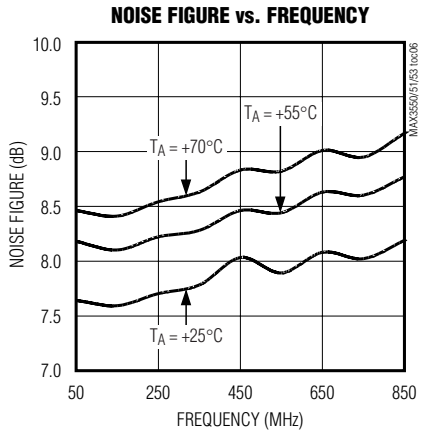
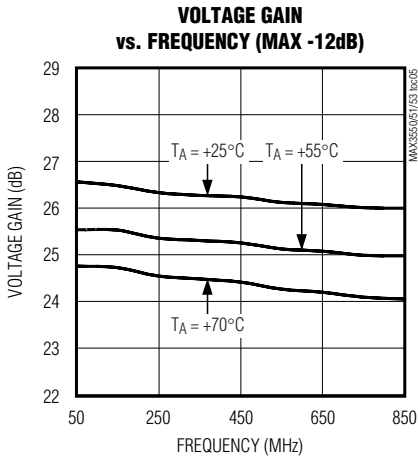
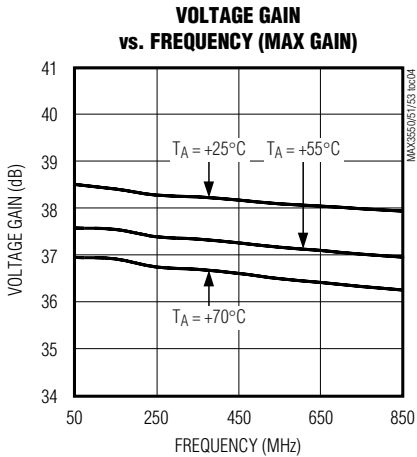
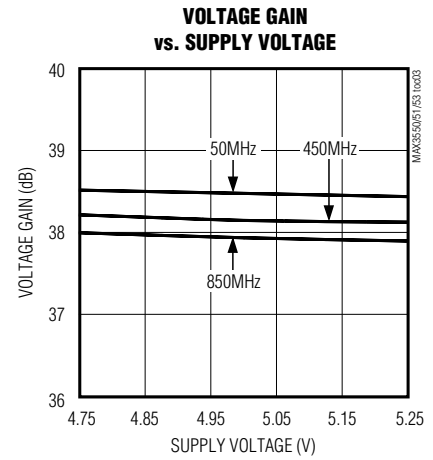
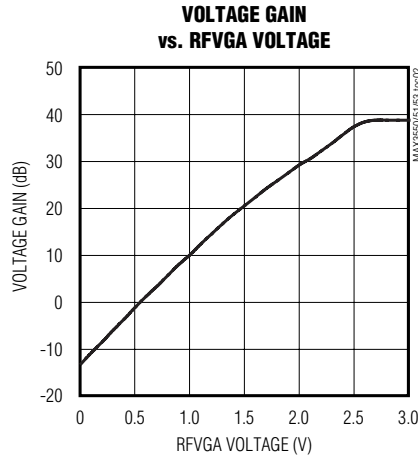
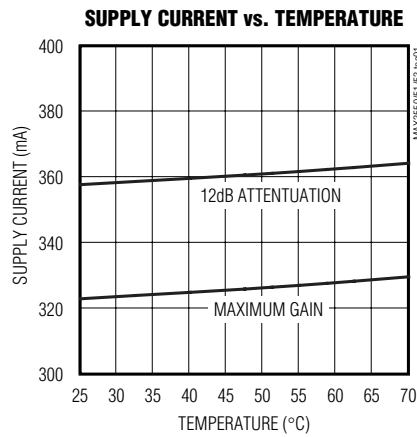

HI-IF Single-Chip Broadband TV Tuners

Typical Operating Characteristics (continued)

(MAX355_EV kit, $V_{CC} = +5.0V$, $R_{BIAS} = 5.9k\Omega$, $f_{RF} = 860MHz$, $f_{IF} = 44MHz$ (MAX3550/MAX3551), $36MHz$ (MAX3553), $T_A = +25^\circ C$, unless otherwise noted.)

MAX3550/MAX3551/MAX3553

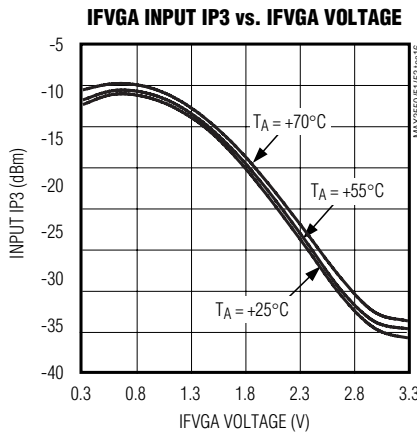
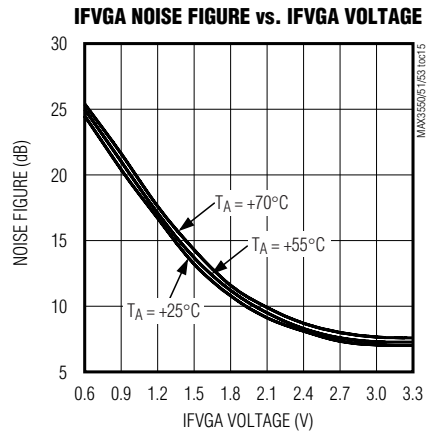
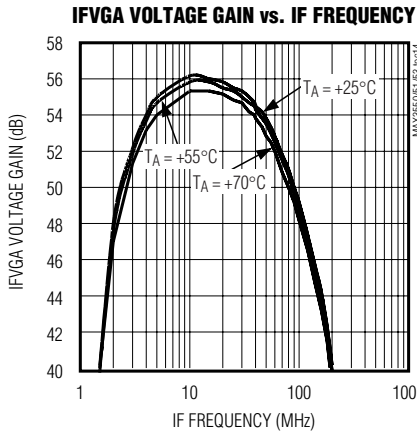
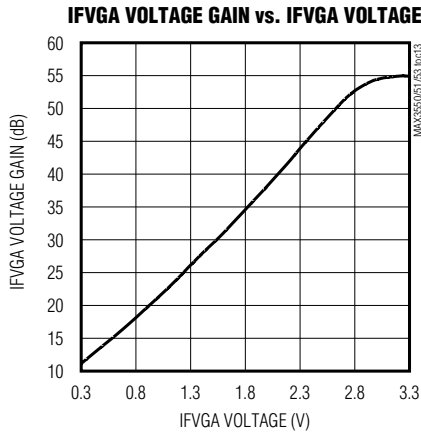
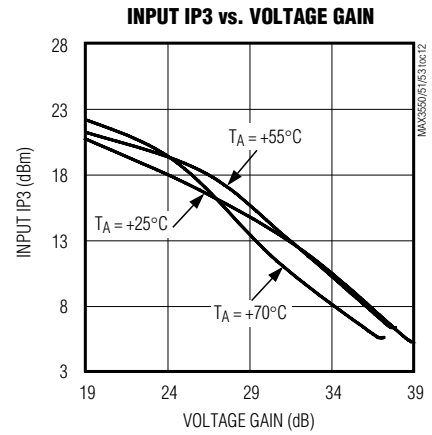
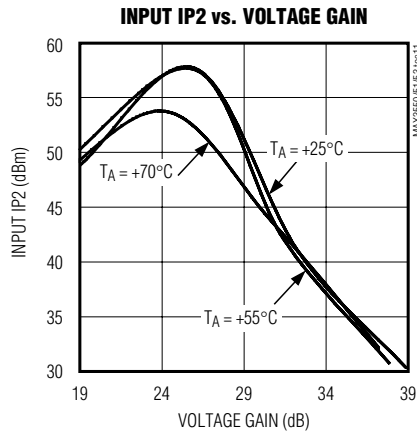
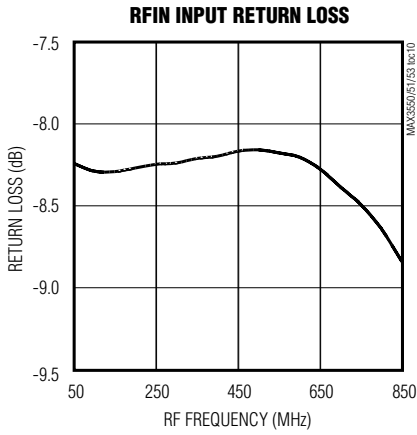

HI-IF Single-Chip Broadband TV Tuners

MAX3550/MAX3551/MAX3553

Pin Description

PIN	NAME	DESCRIPTION
1	V _{CC}	RF Variable-Gain Amplifier (VGA) Supply Voltage. Bypass with a capacitor as close to the pin as possible. Do not share the bypass capacitor ground vias with any other branches.
2, 3	RFIN+, RFIN-	Differential LNA Inputs. Requires AC coupling and can be driven balanced or single ended. Recommend driving pin 3 and AC ground pin 2 for optimum input IP2 performance.
4, 6, 10, 20, 23, 24, 28, 32, 34, 45	GND	Ground. Connect to PC board ground plane.
5	V _{CC}	1st Mixer Supply Voltage. Bypass with a capacitor as close to the pin as possible. Do not share the bypass capacitor ground vias with any other branches.
7	V _{CC}	1st VCO Circuitry Supply Voltage. Bypass with a capacitor as close to the pin as possible. Do not share the bypass capacitor ground vias with any other branches.
8	TUNE1	1st VCO Tuning Input. Connect this analog voltage input to a third-order loop-filter output.
9	LOCFLT1	1st LO Noise-Filtering Capacitor Connection. Connect a capacitor to GND. (Refer to the EV kit.)
11	I.C.	Internal Connection. Leave this pin unconnected (MAX3550).
	ADDR2	2-Wire Serial Interface 2nd Address Pin (MAX3551/MAX3553)
12	\overline{CS}	3-Wire Serial Interface Enable Input Pin (SPI™/QSPI™/MICROWIRE™ Compatible) (MAX3550)
	ADDR1	2-Wire Serial Interface 1st Address Pin (MAX3551/MAX3553)
13	SCL	3-Wire Serial Interface Clock Input Pin (SPI/QSPI/MICROWIRE Compatible) (MAX3550)
		2-Wire Serial Interface Clock Input Pin (MAX3551/MAX3553)
14	SDA	3-Wire Serial Interface Data Input Pin (SPI/QSPI/MICROWIRE Compatible) (MAX3550)
		2-Wire Serial Interface Data Input Pin (MAX3551/MAX3553)
15	V _{CC}	Digital Circuitry Supply Voltage. Bypass with a capacitor as close to the pin as possible. Do not share the bypass capacitor ground vias with any other branches.
16	DIV/LD	Divider or Lock-Detect Logic Output
17	I.C.	Internal Connection. Leave this pin unconnected.
18	CPOUT1	1st PLL Charge-Pump Output. Connect this high-impedance current output to a third-order loop-filter input.
19	V _{CC}	1st Synthesizer Supply Voltage. Bypass with a capacitor as close to the pin as possible. Do not share the bypass capacitor ground vias with any other branches.
21	OSCOUT	Reference Oscillator Buffered Output
22	OSCIN	Reference Oscillator Input. Connect an external reference oscillator or crystal to this analog input through a coupling capacitor.
25	V _{CC}	2nd Synthesizer Supply Voltage. Bypass with a capacitor as close to the pin as possible. Do not share the bypass capacitor ground vias with any other branches.
26	CPOUT2	2nd PLL Charge-Pump Output. Connect this high-impedance current output to a third-order loop-filter input.

SPI and QSPI are trademarks of Motorola, Inc.

MICROWIRE is a trademark of National Semiconductor Corp.

HI-IF Single-Chip Broadband TV Tuners

Pin Description (continued)

PIN	NAME	DESCRIPTION
27	V _{CC}	2nd Charge-Pump Supply Voltage. Bypass with a capacitor as close to the pin as possible. Do not share the bypass capacitor ground vias with any other branches.
29	LOCFLT2	2nd LO Noise-Filtering Capacitor Connector. Connect a capacitor to GND. (Refer to the EV kit.)
30	TUNE2	2nd VCO Tuning Input. Connect this analog voltage input to a third-order loop-filter output.
31	V _{CC}	2nd VCO Circuitry Supply Voltage. Bypass with a capacitor as close to the pin as possible. Do not share the bypass capacitor ground vias with any other branches.
33	V _{CC}	2nd LO Generation Supply Voltage. Bypass with a capacitor as close to the pin as possible. Do not share the bypass capacitor ground vias with any other branches.
35, 36	IFOUT1+, IFOUT1-	1st Differential IF Outputs. These outputs are AC-coupled to the SAW filter inputs.
37	V _{CC}	2nd Mixer and 1st IF Amplifier Circuit Supply Voltage. Bypass with a capacitor as close to the pin as possible. Do not share the bypass capacitor ground vias with any other branches.
38, 39	IFIN+, IFIN-	Differential IF Inputs. Connected to the SAW filter outputs.
40	IFVGA	IF VGA Control. See the <i>Typical Operating Characteristics</i> .
41	V _{CC}	IF VGA Supply Voltage. Bypass with a capacitor as close to the pin as possible. Do not share the bypass capacitor ground vias with any other branches.
42, 43	IFOUT2+, IFOUT2-	IF VGA Outputs
44	V _{CC}	HI-IF Filter Circuit Supply Voltage. Bypass with a capacitor as close to the pin as possible. Do not share the bypass capacitor ground vias with any other branches.
46	BIAS	Bias Resistor Connection. Connect a 5.9k Ω precision $\pm 1\%$ resistor to GND.
47	RFVGA	RF VGA Control. See the <i>Typical Operating Characteristics</i> .
48	LNABIAS	LNA Bias Input. Connect through an inductor to GND. (Refer to the EV kit.)
EP	GND	Exposed Ground Paddle. DC and AC GND return for the IC. Connect to PC board ground plane using multiple vias.

MAX3550/MAX3551/MAX3553

HI-IF Single-Chip Broadband TV Tuners

Detailed Description

Programmable Registers

The MAX3550/MAX3551/MAX3553 include nine programmable registers (registers 1–9) consisting of six divider registers (registers 1–6), one VCO control register (register 7), and one test register (register 8). The final register (register 9) controls the HI-IF filter frequency offset, as well as the DIV/LD output MUX status. Most registers contain some don't care (X) bits. These can be either a "0" or a "1" and do not affect the mode of operation (Table 1). Data is shifted in MSB first. Positive logic is used.

3-Wire Serial Interface

The MAX3550 uses a 3-wire SPI/QSPI/MICROWIRE-compatible serial interface. An active-low chip select (\overline{CS}) enables the device to receive data from the serial input (SDA). Register address and data information are clocked in on the rising edge of the serial clock signal (SCL). While shifting in the serial data, the device remains in its original configuration. A rising edge on \overline{CS} latches the data into the MAX3550's internal register, initiating the device's change of state. Figure 1 shows the details of the 3-wire interface address and data configuration.

Figure 1. 3-Wire Serial Interface Address and Data Configuration

MSB												LSB
4 ADDRESS BITS				8 DATA BITS								
A3	A2	A1	A0	D7	D6	D5	D4	D3	D2	D1	D0	

Figure 2. 2-Wire Serial Interface Register Write Example

START	DEVICE ADDRESS		ACK	REGISTER ADDRESS		ACK	DATA		ACK	DATA		ACK	STOP
	8b11000<ADDR2><ADDR1>0			8b0000XXXX			D7–D0			D7–D0			

Figure 3. 2-Wire Serial Interface Register Read Example

START	DEVICE ADDRESS		ACK	READ BYTE (8 Bits)		NACK	STOP
	8b11000<ADDR2><ADDR1>1			8bXXXXXXXX			

2-Wire Serial Interface

The MAX3551/MAX3553 use a 2-wire I²C*-compatible serial interface. The serial bus is monitored continuously, waiting for a START condition followed by its address. The address has 5 MSB internally set, while the next two bits are set with external pins, ADDR2 and ADDR1. The LSB determines whether it is a read or write. When the device recognizes its address, it acknowledges by pulling the SDA line low for one clock period; it is then ready to accept the register address for the first byte of data. Another acknowledge (ACK) is sent once the register address is received. The device is then ready to accept the data byte. More data bytes can be sent for sequential registers, and ACK is sent after each byte. After the final ACK is sent, the master issues a STOP condition to free the bus. Figure 2 shows the details of the 2-wire interface structure.

There is only one read-back register in the MAX3551/MAX3553. To access it, send a START condition, and then the read address is set by the external ADDR2 and ADDR1 pins. An ACK is sent, and the master then begins to read from the slave. After the eight bits have been read, the master should issue a no-acknowledge (NACK), and then a STOP condition.

Table 1. 2-Wire Serial Interface Address Configuration (Set by ADDR2 and ADDR1)

ADDRESS (WRITE/READ)	ADDR2	ADDR1
C0/C1 _{hex}	Low	Low
C2/C3 _{hex}	Low	High
C4/C5 _{hex}	High	Low
C6/C7 _{hex}	High	High

*Purchase of I²C components of Maxim Integrated Products, Inc., or one of its sublicensed Associated Companies, conveys a license under the Philips I²C Patent Rights to use these components in an I²C system, provided that the system conforms to the I²C Standard Specification as defined by Philips.

I²C is a trademark of Philips Corp.

HI-IF Single-Chip Broadband TV Tuners

MAX3550/MAX3551/MAX3553

Table 2. Register Configuration

REGISTER NUMBER	REGISTER NAME	REGISTER ADDRESS	8 DATA BITS								MSB	LSB
			D7	D6	D5	D4	D3	D2	DB1	D0		
			1	VCO1_N1	00 _{hex}	X	X	X	1N12	1N11	1N10	1N9
2	VCO1_N2	01 _{hex}	1N7	1N6	1N5	1N4	1N3	1N2	1N1	1N0		
3	VCO1_R	02 _{hex}	X	X	X	1R4	1R3	1R2	1R1	1R0		
4	VCO2_N1	03 _{hex}	2N15	2N14	2N13	2N12	2N11	2N10	2N9	2N8		
5	VCO2_N2	04 _{hex}	2N7	2N6	2N5	2N4	2N3	2N2	2N1	2N0		
6	VCO2_R	05 _{hex}	X	2R6	2R5	2R4	2R3	2R2	2R1	2R0		
7	VCO_SET	06 _{hex}	1VCO2	1VCO1	1VCO0	X	1CP1	1CP0	2CP1	2CP0		
8	TEST	07 _{hex}	X	1T4	1T3	1T2	1T1	1T0	ST1	ST0		
9	HI-IF	08 _{hex}	X	X	F1	F0	MUX3	MUX2	MUX1	MUX0		

X = Don't care.

Table 3. Register Description

REGISTER NUMBER	REGISTER NAME	REGISTER ADDRESS	FUNCTION
1	VCO1_N1	00 _{hex}	VCO1 N divide high
2	VCO1_N2	01 _{hex}	VCO1 N divide low
3	VCO1_R	02 _{hex}	VCO1 R divide
4	VCO2_N1	03 _{hex}	VCO2 N divide high
5	VCO2_N2	04 _{hex}	VCO2 N divide low
6	VCO2_R	05 _{hex}	VCO2 R divide
7	VCO_SET	06 _{hex}	VCO select and charge-pump settings
8	TEST	07 _{hex}	Test mode. For test purposes only. Default = 20 _{hex}
9	HI-IF	08 _{hex}	Mode select, MUX output select

Table 4. 1st VCO N-Divider Higher Register (VCO1_N1)

BIT ID	BIT NAME	BIT LOCATION (0 = LSB)	FUNCTION
X	X	7–5	Reserved
1N	1st VCO N-Divider	4–0	1st VCO N-divider MSB bits

Table 5. 1st VCO N-Divider Lower Register (VCO1_N2)

BIT ID	BIT NAME	BIT LOCATION (0 = LSB)	FUNCTION
1N	1st VCO N-Divider	7–0	1st VCO N-divider LSB bits

HI-IF Single-Chip Broadband TV Tuners

Table 6. 1st VCO R-Divider Higher Register (VCO1_R)

BIT ID	BIT NAME	BIT LOCATION (0 = LSB)	FUNCTION
X	X	7–5	Reserved
1R	1st VCO R-Divider	4–0	1st VCO R-divider

Table 7. 2nd VCO N-Divider Higher Register (VCO2_N1)

BIT ID	BIT NAME	BIT LOCATION (0 = LSB)	FUNCTION
2N	2nd VCO N-Divider	7–0	2nd VCO N-divider MSB bits

Table 8. 2nd VCO N-Divider Lower Register (VCO2_N2)

BIT ID	BIT NAME	BIT LOCATION (0 = LSB)	FUNCTION
2N	2nd VCO N-Divider	7–0	2nd VCO N-divider LSB bits

Table 9. 2nd VCO R-Divider Higher Register (VCO2_R)

BIT ID	BIT NAME	BIT LOCATION (0 = LSB)	FUNCTION
X	X	7	Reserved
2R	2nd VCO R-Divider	6–0	2nd VCO R-divider

Table 10. VCO Tank and Charge-Pump Select Register (VCO_SET)

BIT ID	BIT NAME	BIT LOCATION (0 = LSB)	FUNCTION
1VCO	1st VCO Tank Select	7, 6, 5	1st VCO Tank Select: <ul style="list-style-type: none"> • 000 = 1st VCO tank (the lowest frequency oscillator) • 001 = 2nd VCO tank • 010 = 3rd VCO tank • 011 = 4th VCO tank • 100 = 5th VCO tank • 101 = 6th VCO tank • 110 = 7th VCO tank • 111 = 8th VCO tank (the highest frequency oscillator)
X	X	4	Reserved
1CP	1st VCO Charge-Pump Current	3, 2	1st VCO Charge-Pump Current: <ul style="list-style-type: none"> • 00 = 0.2mA • 01 = 0.4mA • 10 = 0.6mA • 11 = 0.8mA
2CP	2nd VCO Charge-Pump Current	1, 0	2nd VCO Charge-Pump Current: <ul style="list-style-type: none"> • 00 = 0.2mA • 01 = 0.4mA • 10 = 0.6mA • 11 = 0.8mA

HI-IF Single-Chip Broadband TV Tuners

MAX3550/MAX3551/MAX3553

Table 11. HI-IF Step Control and MUX Output Register (HI-IF)

BIT ID	BIT NAME	BIT LOCATION (0 = LSB)	FUNCTION
X	X	7, 6	Reserved
F	HI-IF Filter Control	5, 4	HI-IF Filter Control: <ul style="list-style-type: none"> • 00 = Step down 5MHz • 01 = Nominal • 11 = Step up 5MHz
MUX	Lock-Detect and MUX Output Control	3-0	Lock-Detect and MUX Output Control: <ul style="list-style-type: none"> • 0000 = Normal, low-noise operation • 0001 = Lock detect for the 1st VCO • 0010 = Lock detect for the 2nd VCO • 0011 = 1st VCO N-divider • 0100 = 1st VCO R-divider • 0101 = 2nd VCO N-divider • 0110 = 2nd VCO R-divider • 0111 = Reference oscillator • 1000 = AND output of lock detector • 1001 = NAND output of lock detector • 1010 = 1st VCO VTUNE over/under indicator • 1011 = 2nd VCO VTUNE over/under indicator

Table 12. Read Mode Register Configuration

REGISTER NUMBER	REGISTER NAME	8 DATA BITS							
		D7	D6	D5	D4	D3	D2	DB1	D0
		1	LD_POR	LOCK1	LOCK2	POR	OU1	OU2	X

Table 13. Read Mode Register Description

REGISTER NUMBER	REGISTER NAME	FUNCTION
1	LD_POR	Lock detect and power-on reset

Table 14. Lock Detect and POR Register

BIT ID	BIT NAME	BIT LOCATION (0 = LSB)	FUNCTION
LOCK1	LOCK1	7	Lock indicator for 1st VCO (see Table 15)
LOCK2	LOCK2	6	Lock indicator for 2nd VCO
POR	POR	5	Power-on reset indicator. 1 indicates successful power-on reset.
OU1	OU1	4	Over or Under VTUNE indicator for 1st VCO (see Table 15)
OU2	OU2	3	Over or Under VTUNE indicator for 2nd VCO
X	X	2, 1, 0	Reserved

Table 15. 1st VCO Truth Table

LOCK1	OU1	DESCRIPTION
1	x	1st VCO Locked
0	0	(Under) Choose next lower tank
0	1	(Over) Choose next higher tank

HI-IF Single-Chip Broadband TV Tuners

MAX3550/MAX3551/MAX3553

Typical Application Circuit

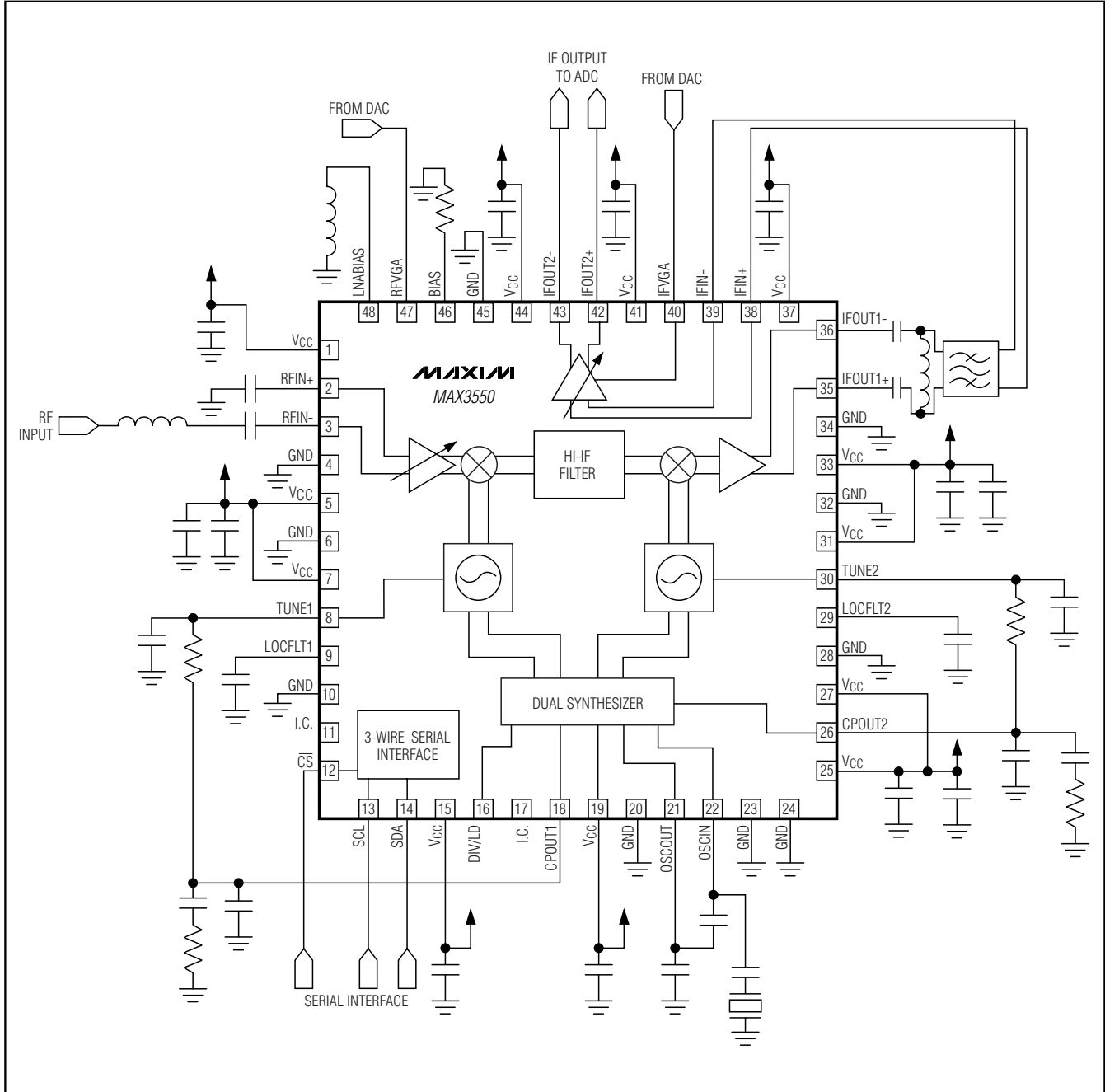

HI-IF Single-Chip Broadband TV Tuners

MAX3550/MAX3551/MAX3553

Applications Information

RF Input

An LNA provides a single-ended broadband input matched to a 75Ω source. It provides a linear, continuous gain-control range of over 30dB before the signal is upconverted. A 10nH inductor in series with a 1000pF capacitor is required at the RF input (pin 3) to achieve optimal matching (see the *Typical Application Circuit*).

HI-IF Frequency Agility

In a double conversion receiver, beat frequencies are generated from harmonics of the LOs associated with this system. In some instances these beat frequencies may coincide with the IF. If this occurs, it is possible to shift the HI-IF slightly by retuning the LOs. This shift moves the beat out of the IF band. The MAX3550/MAX3351/MAX3553 support this capability by allowing the user to shift the center frequency of the HI-IF filter slightly, tracking the shift in the LO frequencies, preserving the optimum image rejection and insertion loss. The HI-IF filter frequency shift is controlled with the HI-IF filter step control bits (F0 and F1, register address 8). (*Patent pending.*)

IF Outputs

A first differential IF output (IFOUT1+, IFOUT1-), although intended to drive a standard IF SAW filter, is capable of driving loads as low as 200Ω . A second differential IF output (IFOUT2+, IFOUT2-) provides a balanced output capable of driving loads as low as 300Ω and can be AC-coupled to a standard QAM demodulator's ADC.

Gain Control

The MAX3550/MAX3551/MAX3553 have two VGA circuits that are used to achieve the optimum SNR while minimizing distortion. At low input signal levels the RFVGA voltage should be 3.0V. This sets the LNA gain at its maximum. The IFVGA control voltage is used to set the required output signal level. As the RF input level increases, the IFVGA voltage drops. When the IFVGA voltage reaches a user-defined value (RFVGA attack point), the IFVGA voltage is frozen and the RFVGA voltage is adjusted to maintain the desired output level.

VCO1 Selection

VCO1 generates the first local oscillator (LO1) frequency for the upconverting mixer. It consists of an array of eight VCOs; each tuned to a unique frequency band, to cover the required frequency range. The desired VCO is chosen through the serial data interface (SDI). Please refer to Application Note: *MAX3550/MAX3551/MAX3553 VCO Selection* for further information on VCO1 VCO selection.

Synthesizer Comparison Frequency Selection

The two on-chip synthesizers of the MAX3550/MAX3551/MAX3553 are capable of supporting a wide range of comparison frequencies. The PLL for the first LO (LO1) provides a comparison frequency range from below 250kHz up to 4MHz, assuming a 4MHz reference (crystal) frequency. The second LO (LO2) PLL supports a comparison frequency range from below 50kHz up to 2MHz, again assuming a 4MHz reference.

Comparison frequencies of 1MHz for LO1 ($R1 = 4$) and 250kHz for LO2 ($R2 = 16$) are recommended for the MAX3550 and MAX3551. For the MAX3553, the recommended LO2 comparison frequency is 142.8571kHz ($R2 = 28$, 4MHz crystal frequency). These values ensure optimum resolution while working with the loop filters to suppress spurious energy and provide acceptable lock time.

Synthesizer Loop Filters

A third-order lowpass loop filter is used for each local oscillator to achieve low spurious and low phase noise. The loop bandwidth is chosen so the spurious rejection is sufficient and a reasonable lock time is achieved. Refer to the EV kit for the recommended loop-filter component values.

Crystal Oscillator Interface

The crystal oscillator pins (OSCIN, OSCOUT) must be connected to a crystal or an external reference oscillator. When connecting directly to a crystal, refer to the EV kit for the recommended component values. When using an external reference oscillator, drive OSCIN with amplitude of 1.5V_{p-p}, and leave OSCOUT unconnected.

Power-Supply Layout

To minimize coupling between different sections of the IC, the ideal power-supply layout is a star configuration, which has a large decoupling capacitor at a central VCC node. The VCC traces branch out from this node, each going to a separate VCC node in the MAX3550/MAX3551/MAX3553 circuit. At the end of each trace is a bypass capacitor with a low impedance to ground at the frequency of interest. This arrangement provides local decoupling at each VCC pin. Use at least one via per bypass capacitor for a low-inductance ground connection.

HI-IF Single-Chip Broadband TV Tuners

Pin Configurations/ Functional Diagrams (continued)

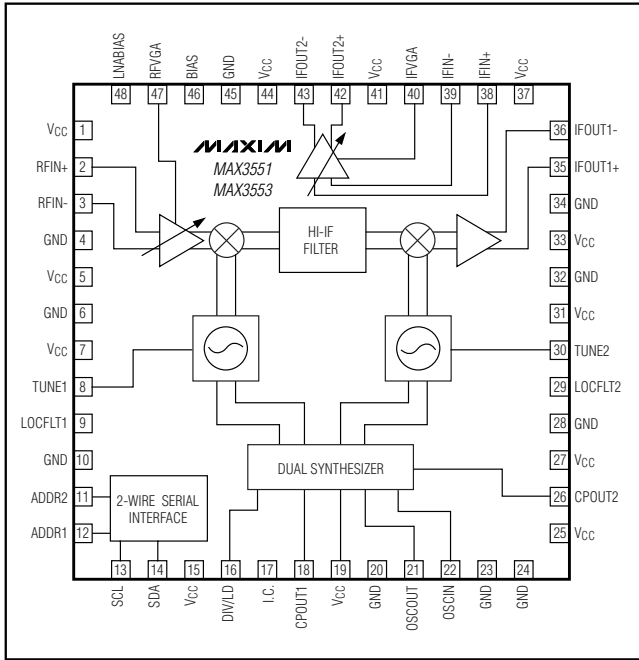

Matching Network Layout

The layout of a matching network can be very sensitive to parasitic circuit elements. To minimize parasitic inductance, keep all traces short and place components as close to the IC as possible. To minimize parasitic capacitance, a cutout in the ground plane (and any other planes) below the matching network components can be used. Refer to the EV kit for recommended input matching network.

Chip Information

TRANSISTOR COUNT: 18,970
PROCESS: SiGe BiCMOS

HI-IF Single-Chip Broadband TV Tuners

Package Information

(The package drawing(s) in this data sheet may not reflect the most current specifications. For the latest package outline information, go to www.maxim-ic.com/packages.)

MAX3550/MAX3551/MAX3553

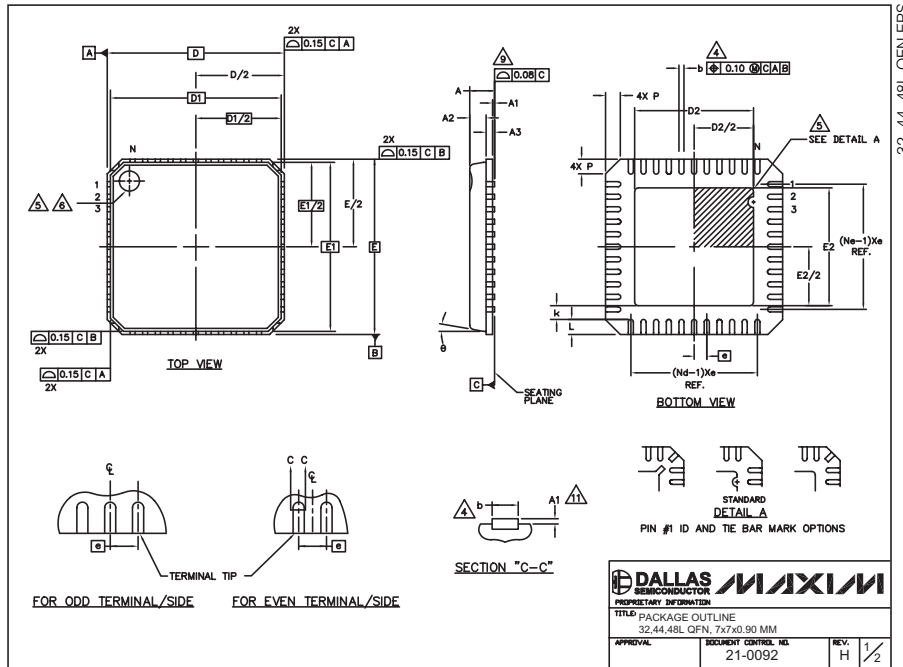

COMMON DIMENSIONS									
PKG	32L 7x7			44L 7x7			48L 7x7		
SYMBOL	MIN.	NDM.	MAX.	MIN.	NDM.	MAX.	MIN.	NDM.	MAX.
A	0.80	0.90	1.00	0.80	0.90	1.00	0.80	0.90	1.00
A1	0.00	0.01	0.05	0.00	0.01	0.05	0.00	0.01	0.05
A2	0.00	0.65	1.00	0.00	0.65	1.00	0.00	0.65	1.00
A3	0.20 REF			0.20 REF			0.20 REF		
b	0.23	0.28	0.35	0.18	0.23	0.30	0.18	0.23	0.30
D	6.90	7.00	7.10	6.90	7.00	7.10	6.90	7.00	7.10
D1	6.75 BSC			6.75 BSC			6.75 BSC		
E	6.90	7.00	7.10	6.90	7.00	7.10	6.90	7.00	7.10
E1	6.75 BSC			6.75 BSC			6.75 BSC		
e	0.65 BSC			0.50 BSC			0.50 BSC		
k	0.25	-	-	0.25	-	-	0.25	-	-
L	0.35	0.55	0.75	0.35	0.55	0.75	0.30	0.40	0.50
N	32			44			48		
Nd	8			11			12		
Ne	8			11			12		
P	0.00	0.42	0.60	0.00	0.42	0.60	0.00	0.42	0.60
U	0"			12"			0"		

EXPOSED PAD VARIATIONS						
PKG CODES	D2			E2		
	MIN.	NDM.	MAX.	MIN.	NDM.	MAX.
G3277-2	4.55	4.70	4.85	4.55	4.70	4.85
G4477-1	3.65	3.80	3.95	3.65	3.80	3.95
G4477-2	4.55	4.70	4.85	4.55	4.70	4.85
G4477-3	3.15	3.30	3.45	3.15	3.30	3.45
G4877-1	4.95	5.10	5.25	4.95	5.10	5.25
G4877-2	5.45	5.60	5.75	5.45	5.60	5.75

NOTES:

- DIE THICKNESS ALLOWABLE IS 0.305mm MAXIMUM (.012 INCHES MAXIMUM).
- DIMENSIONING & TOLERANCES CONFORM TO ASME Y14.5M. - 1994.
- N IS THE NUMBER OF TERMINALS. Nd IS THE NUMBER OF TERMINALS IN X-DIRECTION & Ne IS THE NUMBER OF TERMINALS IN Y-DIRECTION.
- DIMENSION b APPLIES TO PLATED TERMINAL AND IS MEASURED BETWEEN 0.20 AND 0.25mm FROM TERMINAL TIP.
- THE PIN #1 IDENTIFIER MUST EXIST ON THE TOP SURFACE OF THE PACKAGE BY USING INDENTATION MARK OR INK/LASER MARKED. DETAILS OF PIN #1 IDENTIFIER IS OPTIONAL, BUT MUST BE LOCATED WITHIN ZONE INDICATED.
- EXACT SHAPE AND SIZE OF THIS FEATURE IS OPTIONAL.
- ALL DIMENSIONS ARE IN MILLIMETERS.
- PACKAGE WARPAGE MAX 0.08mm.
- APPLIED FOR EXPOSED PAD AND TERMINALS. EXCLUDE EMBEDDED PART OF EXPOSED PAD FROM MEASURING.
- MEETS JEDEC MO220 EXCEPT DIMENSION "b" MINIMUM.
- APPLY ONLY FOR TERMINAL.
- THIS PACKAGE OUTLINE APPLIES TO ANVIL SINGULATION(STEPED SIDES).

Maxim cannot assume responsibility for use of any circuitry other than circuitry entirely embodied in a Maxim product. No circuit patent licenses are implied. Maxim reserves the right to change the circuitry and specifications without notice at any time.

Maxim Integrated Products, 120 San Gabriel Drive, Sunnyvale, CA 94086 408-737-7600 17